

Kenny, D. A., Archambault, F. X., Jr., & Hallmark, B. W. (1995). *The effects of group composition on gifted and non-gifted elementary students in cooperative learning groups* (Research Monograph 95116). University of Connecticut, The National Research Center on the Gifted and Talented. <https://nrcgt.uconn.edu/wp-content/uploads/sites/953/2015/04/rm95116.pdf>

Science Curriculum Worksheets

Static Electricity Teamsheet

Team Color: _____

As a group, use the items in your electricity kit to conduct the experiments. Record your observations on the sheet.

1. Hold the balloon near the puffed rice. What happens to the rice?

2. Rub the balloon with the piece of cloth and hold the balloon near the puffed rice. What happens to the rice?

3. What did you have to do to the balloon before it had an effect on the puffed rice?

4. Place some puffed rice in the plastic bag. Blow air into the bag. Tie the end. Rub the bag with the cloth. What happens to the rice?

Kenny, D. A., Archambault, F. X., Jr., & Hallmark, B. W. (1995). *The effects of group composition on gifted and non-gifted elementary students in cooperative learning groups* (Research Monograph 95116). University of Connecticut, The National Research Center on the Gifted and Talented. <https://nrcgt.uconn.edu/wp-content/uploads/sites/953/2015/04/rm95116.pdf>

5. Rub the bag and the balloon with the cloth. Bring the balloon near the side of the bag. What happens to the rice?

5a. Why does this happen? _____

6. How did you create more static electricity?

Using the diagram, answer the following questions.

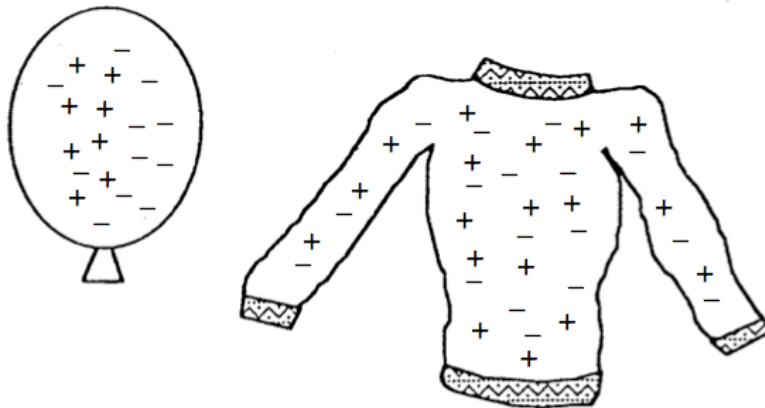

7. What can you tell us about this picture of the balloon and the sweater?

8. How did the balloon get the extra electrons? _____

Kenny, D. A., Archambault, F. X., Jr., & Hallmark, B. W. (1995). *The effects of group composition on gifted and non-gifted elementary students in cooperative learning groups* (Research Monograph 95116). University of Connecticut, The National Research Center on the Gifted and Talented. <https://nrcgt.uconn.edu/wp-content/uploads/sites/953/2015/04/rm95116.pdf>

Current Electricity Teamsheet

Team Color: _____

Conduct the following experiments by using the materials located in today's baggy bag. Use the space provided to record your observations.

1. Using **one battery** and **one wire**, try to light the bulb.

Answer each question.

Does the bulb have to be touching the battery? **Yes** **No**

Does the wire have to be wrapped around the bulb? **Yes** **No**

Mark the two special places on the bulb that must be touched in order for it to light.



What locations on the battery have to be touched? Mark them with an X.



Kenny, D. A., Archambault, F. X., Jr., & Hallmark, B. W. (1995). *The effects of group composition on gifted and non-gifted elementary students in cooperative learning groups* (Research Monograph 95116). University of Connecticut, The National Research Center on the Gifted and Talented. <https://nrcgt.uconn.edu/wp-content/uploads/sites/953/2015/04/rm95116.pdf>

2. Using one battery, one wire, and the bulb, **draw many different ways** that your group can make the bulb light. You can use the masking tape to hold the wires in place.

3. Make connections using **a battery, bulb, and 2 wires**. Sketch the many connections which make the bulb light.

Kenny, D. A., Archambault, F. X., Jr., & Hallmark, B. W. (1995). *The effects of group composition on gifted and non-gifted elementary students in cooperative learning groups* (Research Monograph 95116). University of Connecticut, The National Research Center on the Gifted and Talented. <https://nrcgt.uconn.edu/wp-content/uploads/sites/953/2015/04/rm95116.pdf>

4. Look at each of the following pictures and decide if the bulb will light. Before you test the circuit, predict what you think may happen. Use “Yes” or “No” as your answer.

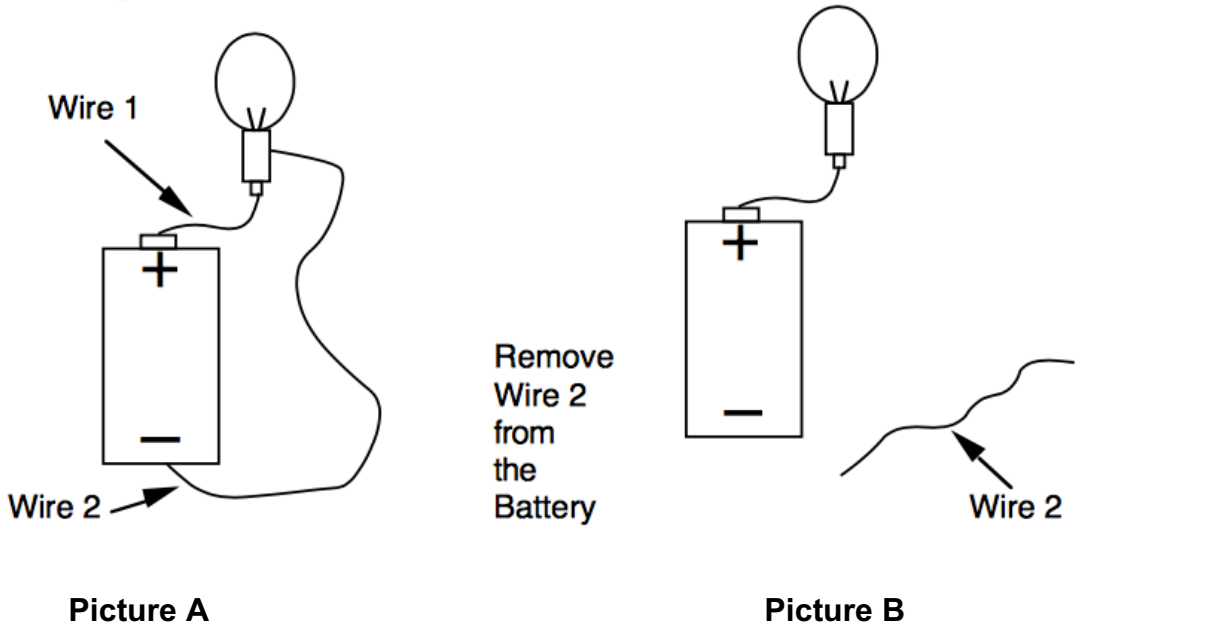

Picture A
 Prediction #1 _____
 Result _____

Picture B
 Prediction #2 _____
 Result _____

- 4a. Circle the picture A or B that shows the bulb lighting.
- 4b. Why didn't the bulb in the other picture light?
- _____
- 4c. Which picture shows a complete circuit Picture A or Picture B?
- _____
- 4d. Explain why a bulb does not light when the circuit is broken using the words **flow electrons, and protons**.
- _____
- _____
- _____

Kenny, D. A., Archambault, F. X., Jr., & Hallmark, B. W. (1995). *The effects of group composition on gifted and non-gifted elementary students in cooperative learning groups* (Research Monograph 95116). University of Connecticut, The National Research Center on the Gifted and Talented. <https://nrcgt.uconn.edu/wp-content/uploads/sites/953/2015/04/rm95116.pdf>

5. Identify which bulbs light and don't light by using the words **yes** and **no**.

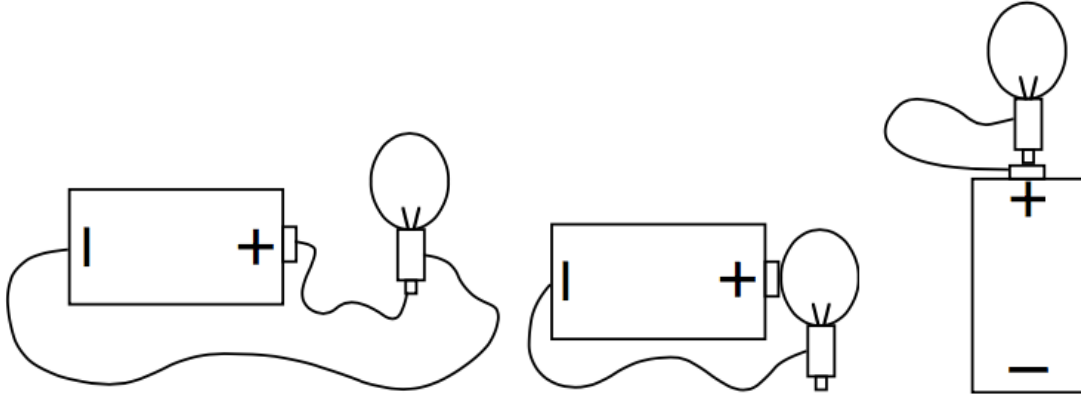

6. Using **two or more batteries**, light the bulb. Draw the picture that show the connections which make the bulbs light.

7. Light the bulb with **one** battery. Now light the bulb with **two** batteries. See the picture below.
What happens to the bulb when you use two or more batteries?

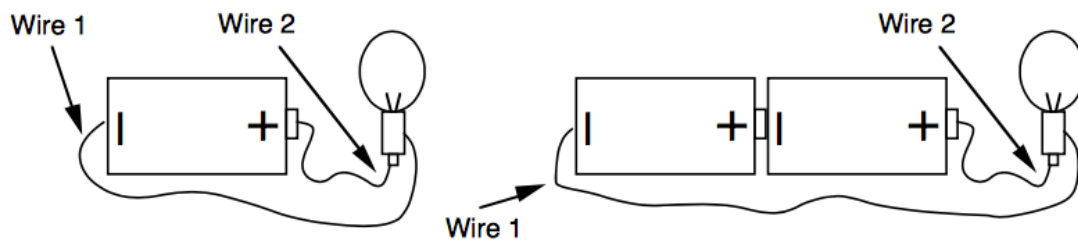

Kenny, D. A., Archambault, F. X., Jr., & Hallmark, B. W. (1995). *The effects of group composition on gifted and non-gifted elementary students in cooperative learning groups* (Research Monograph 95116). University of Connecticut, The National Research Center on the Gifted and Talented. <https://nrcgt.uconn.edu/wp-content/uploads/sites/953/2015/04/rm95116.pdf>

8. In this picture, the circuit is incomplete. This small gap will stop the current flow and the bulb will not light. Experiment with some of the materials in your baggy bag and see which object can be used to complete the circuit and light the bulb. The objects that help you to light the bulb are called conductors and the objects that don't help to light the bulb are called insulators. Use the chart to record your observations.

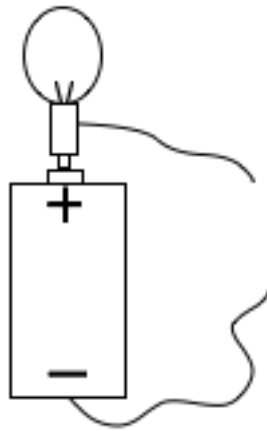

Conductor	Insulator

9. Look at your chart, what are all of the conductors made from?

Kenny, D. A., Archambault, F. X., Jr., & Hallmark, B. W. (1995). *The effects of group composition on gifted and non-gifted elementary students in cooperative learning groups* (Research Monograph 95116). University of Connecticut, The National Research Center on the Gifted and Talented. <https://nrcgt.uconn.edu/wp-content/uploads/sites/953/2015/04/rm95116.pdf>

10. Explain why conductors let a bulb light and insulators do not let a bulb light. Use the words: **Flow, electrons, circuit, conductors, and insulators.**

Electromagnets Teamsheet

Team Color: _____

1. Use two wires to make the bulb light with one battery holder and the bulb holder. Draw lines where you put the two wires.

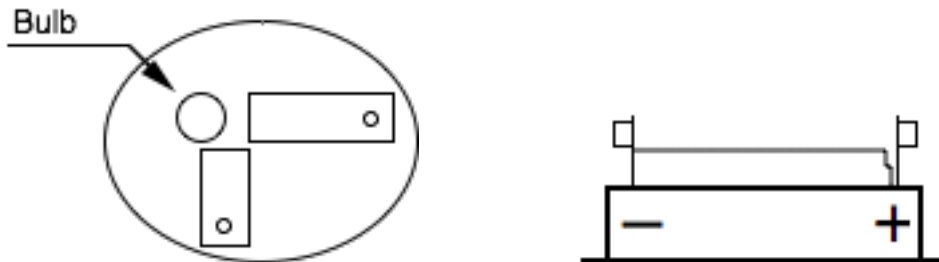

2. Now light the bulb using two batteries and the bulbholder. SEE THE PICTURE BELOW.

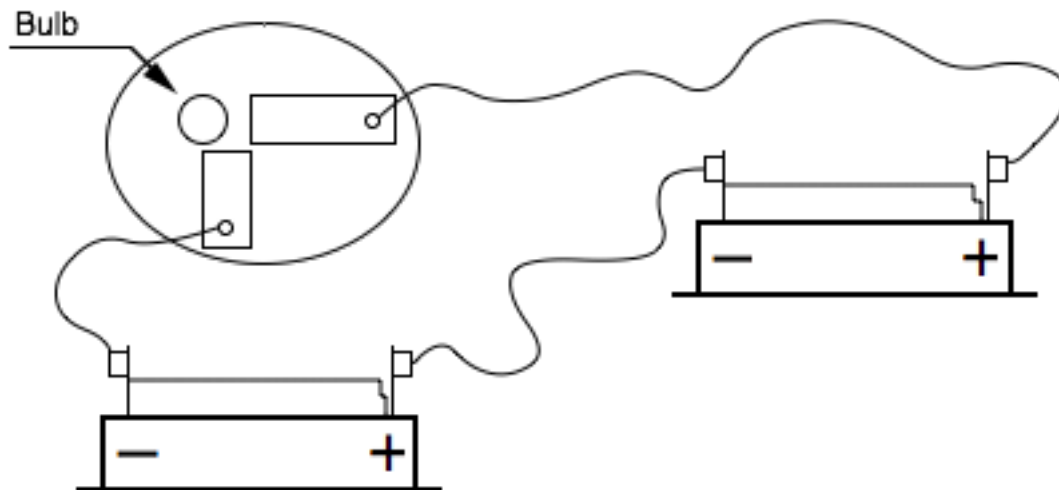

Kenny, D. A., Archambault, F. X., Jr., & Hallmark, B. W. (1995). *The effects of group composition on gifted and non-gifted elementary students in cooperative learning groups* (Research Monograph 95116). University of Connecticut, The National Research Center on the Gifted and Talented. <https://nrcgt.uconn.edu/wp-content/uploads/sites/953/2015/04/rm95116.pdf>

2a. Is the bulb brighter with one or two batteries?

2b. Why does this happen? Use the word POWER in your sentence.

3. **Without hooking up the nail to the battery**, take one of the nails and try to pick up some paperclips. What happens?

Remove the bulbholder from the battery holder.

4. Take the nail that is marked 20. Attach one wire from the nail to the battery holder. Attach the other wire from the nail to the other end of the battery holder. SEE THE PICTURE BELOW.

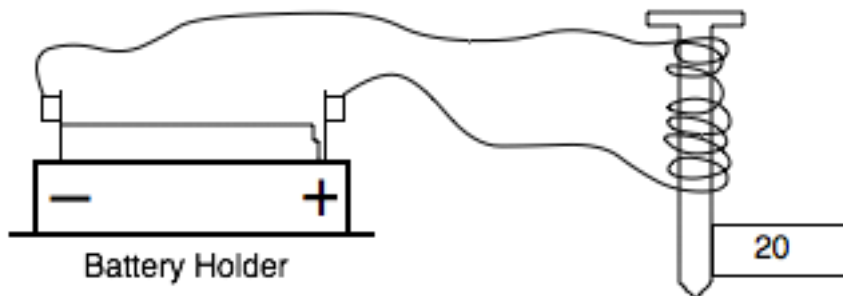

5. Now try to pick up some paperclips using the nail. How many paperclips does the nail pick up?

6. Now try to pick up some paperclips using the nail marked 40. How many paperclips does the nail pick up?

Kenny, D. A., Archambault, F. X., Jr., & Hallmark, B. W. (1995). *The effects of group composition on gifted and non-gifted elementary students in cooperative learning groups* (Research Monograph 95116). University of Connecticut, The National Research Center on the Gifted and Talented. <https://nrcgt.uconn.edu/wp-content/uploads/sites/953/2015/04/rm95116.pdf>

7. Which nail picks up the most paperclips? 20 or 40

7a. Why did this happen?

8. Using two batteries and the nail marked 40, pick up some paperclips. SEE THE PICTURE BELOW.

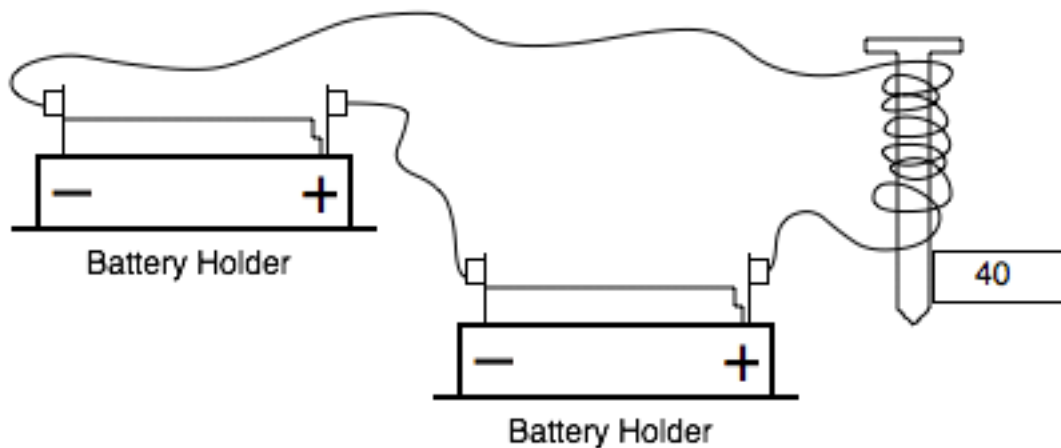

8a. How many paperclips does the nail pick up? _____

8b. Which magnet is stronger the one with two batteries or one battery?

One or Two (CIRCLE ONE)

Kenny, D. A., Archambault, F. X., Jr., & Hallmark, B. W. (1995). *The effects of group composition on gifted and non-gifted elementary students in cooperative learning groups* (Research Monograph 95116). University of Connecticut, The National Research Center on the Gifted and Talented. <https://nrcgt.uconn.edu/wp-content/uploads/sites/953/2015/04/rm95116.pdf>

9. What are the two things that make an electromagnet stronger?

10. Using the words ELECTRON FLOW and POWER explain why some magnets are stronger than others.
